

TSL.882

IR sensor tap

installation + maintenance

+ THE
SPLASH
LAB

contents

3	Safety and Warnings
4	Box Contents
5	Technical Data
7	Before You Install
11	How to Install
16	Commissioning
17	The Complete System
18	Settings Adjustment: Wired Controller
19	Maintenance
24	Cleaning
25	Diagram
26	Troubleshooting
28	Warranty
29	Spare Parts / Accessories
30	Drilling Template
31	Contact Details

TSL. 882 sensor tap

Read and save these instructions

WARNING

To reduce the risk of fire, electric shock or injury to persons, observe the following:

- + Use this unit only in the manner intended by the manufacturer. If you have questions, contact the manufacturer (see back page for more details).
- + Replace batteries only with the same type and rating of batteries.
- + Disconnect power supply before performing any maintenance on product.
- + Ensure wiring is installed correctly before connecting to power supply (see installation instructions, page 11, for details).
- + Keep plugs and receptacles dry.
- + All plumbing is to be installed in accordance with applicable codes and regulations.

For more information contact:

Tel: +1 310 410 5008

Email: technical@thesplashlab.com

box contents

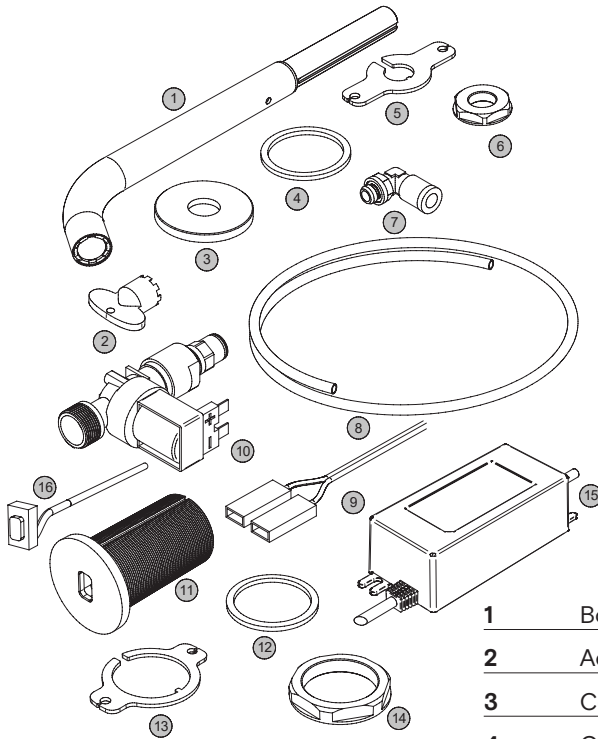

- | | |
|----|--|
| 1 | Body |
| 2 | Aerator key |
| 3 | Collar |
| 4 | Gasket (Collar) |
| 5 | Anti-rotation washer (Spigot) |
| 6 | Locking nut (Spigot) |
| 7 | Elbow fitting |
| 8 | Inlet tubing |
| 9 | Solenoid valve cable |
| 10 | Solenoid valve assembly |
| 11 | Sensor Housing |
| 12 | Gasket (Sensor Housing) |
| 13 | Anti-rotation washer
(Sensor Housing) |
| 14 | Locking nut (Sensor Housing) |
| 15 | Power Supply |
| 16 | IR Sensor |

technical data

Finishes	TSL .882BK Brushed Black
	TSL .882BR Brushed Brass
	TSL .882BZ Brushed Bronze
	TSL .882CP Brushed Copper
	TSL .882CS Brushed Stainless Steel

MECHANICAL

Body Material	AISI 304 Stainless Steel
Coating Type	PVD
Aerator	Cascade
Water Pressure (Dynamic)	7.5 - 108psi
Water Temperature (max)	140 °F
Flow Rates	0.5gpm Also available as optional extras: 0.35gpm 1.00gpm

ELECTRICAL

Power supply	110-230 Vac, 50-60Hz, 1.5A
Output (max)	6 Vdc, 1A
Power consumption	< 87% Active mode, 0.3W No load
Solenoid valve type	6V Latching
Water Ingress	IP55
Cable lengths	31 1/2" – Power supply connection 31 1/2" – Solenoid valve connection

technical data

SENSOR FUNCTION

Sensor type	Infrared
Pre-set sensor range	8 11/16"
Sensor range (max)	9 13/16"
Tolerance on range	± 20%
Comfort delay	2 sec
Security time-out	30 sec
Operating Temperature	32 to 122 °F
Response Time (max)	0.3 - < 1 sec
Tolerance on times	± 20%

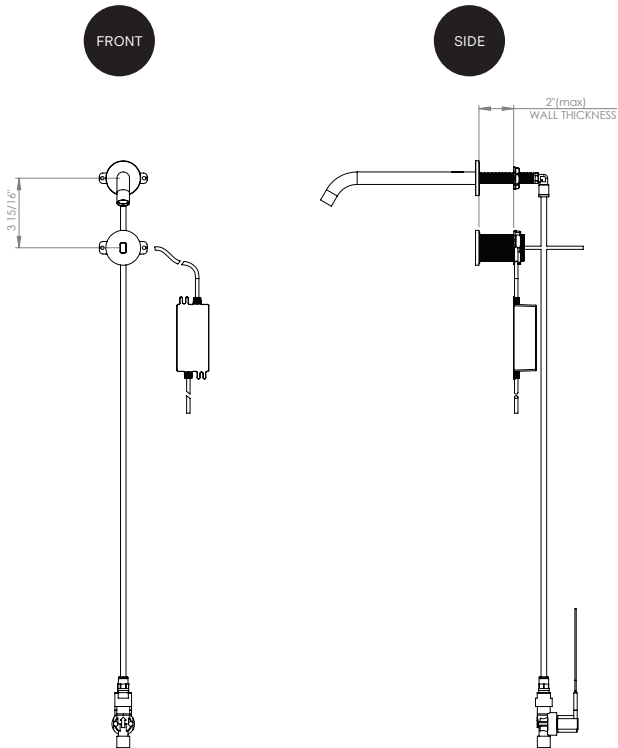

before you install

Power Supply

The TSL .882 IR Sensor Tap system is provided with a mains power supply (110-240Vac transformer) compatible for European and North American markets which requires wiring into a fused connection unit (FCU) or spur.

To reduce installation costs the power supply can be wired into a junction box (not supplied) and then fed directly into a FCU or distribution board.

Water Supply

Flush water supply lines thoroughly before installing the tap. Do not allow dirt, Teflon tape or metal particles to enter the tap. Shut off the water supply before installation. Gravity-fed systems may require a booster pump to achieve the optimal operating pressure.

Flow Rates

The aerator supplied as standard has a flow rate of 0.50gpm. However, different flow rates may need to be achieved and The Splash Lab offer alternatives with flow rates of 0.35gpm and 1.0gpm respectively. Refer to Spare Parts & Accessories (page 29) for more information.

before you install

Access Requirements

It is critical all components which require fixing behind the wall are easily accessible at all times during installation and routine maintenance.

Wall Cavity: a minimum cavity depth of $3\ 15/16"$ is recommended to ensure enough clearance for installing and commissioning tap components, connecting to mains water supply and safe installation of power supply.

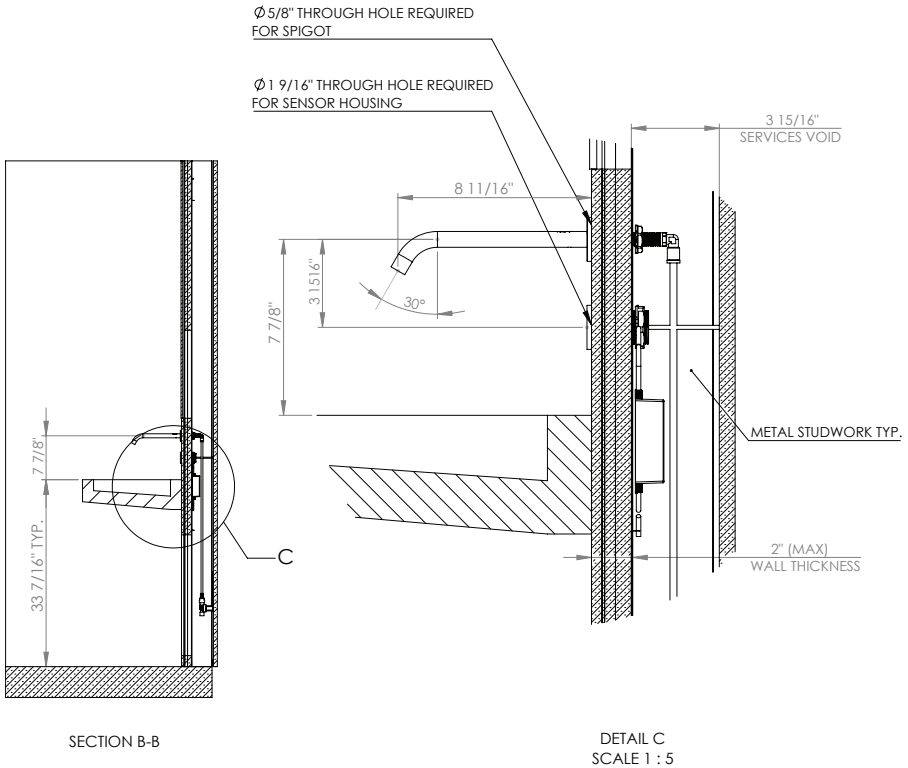

Access Requirements

Front access: a hatch or panel(s) must be constructed either below the washbasin or behind the mirror to ensure the tap, solenoid valve, isolation valves and power supply are accessible.

ACCESSIBILITY REQUIREMENTS

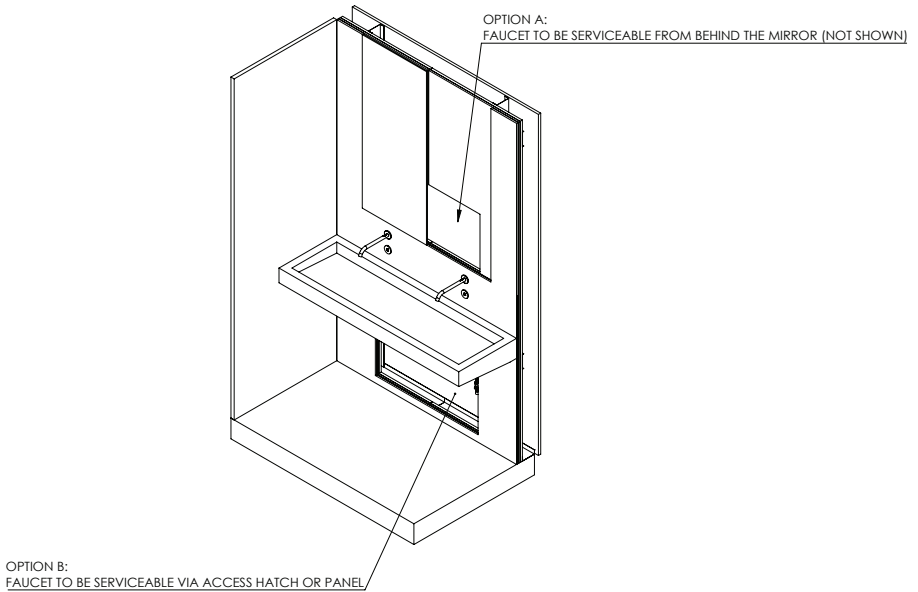

Ensure access hatches below the washbasin and/or behind the mirror are accounted for to ensure easy access of components during installation and for routine maintenance.

before you install

Mounting Location

- + The maximum wall thickness the tap can be mounted to is 2" (incl. all finishes).
- + The recommended distance from the centre of the spout to the countertop of the washbasin is 8".
- + The distance between the centres of the spout and sensor housing is 3 15/16"
- + Ensure the holes and appropriate mounting points are created in accordance with the 1:1 drilling template shown on page 30.
- + Taps should not be installed above highly polished surfaces to avoid reflection interference

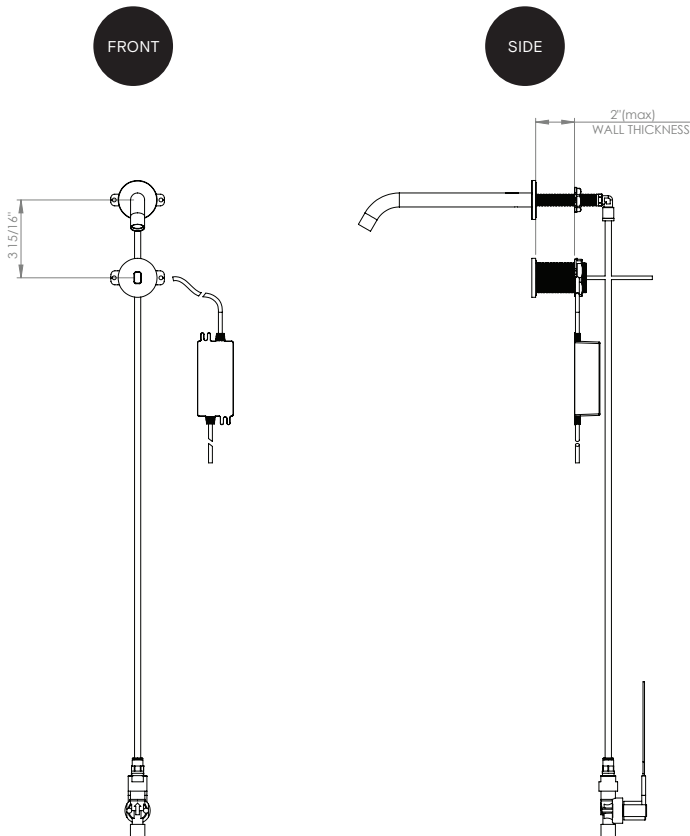

how to install

Tap & Sensor Housing Installation

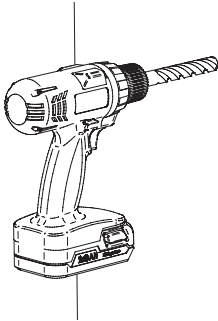

1

Drill a $\text{\O}5/8$ " hole through the mounting surface and into the wall cavity.

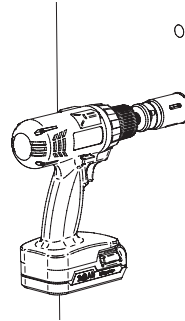

2

Drill a $\text{\O}19/16$ " hole through the mounting surface and into the wall cavity.

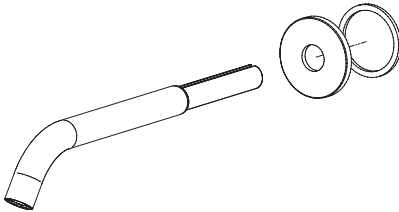

3

Slide the collar and gasket over the spigot

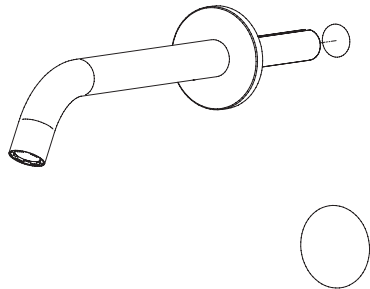

4

Slot the spigot end of the tap through the pre-drilled hole

how to install

Tap & Sensor Housing Installation

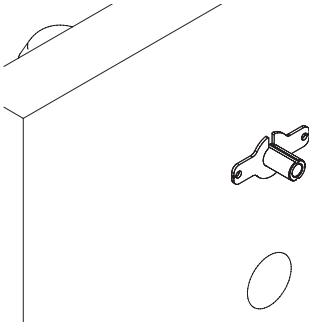

5

Fit the anti-rotational washer over the spigot.

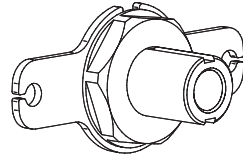

6

Thread the locking nut onto the spigot until hand tight

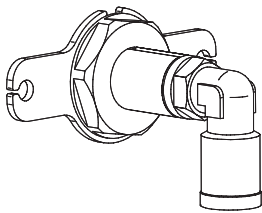

7

Tighten plastic elbow fitting into the spigot and tighten with a wrench.

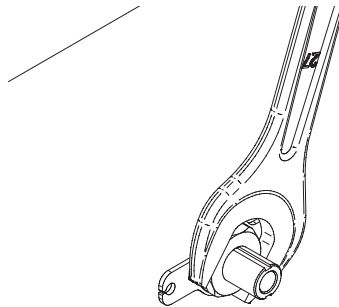

8

Tighten locking nut with a wrench and check spout of tap is aligned correctly from the front.

Tap & Sensor Housing Installation

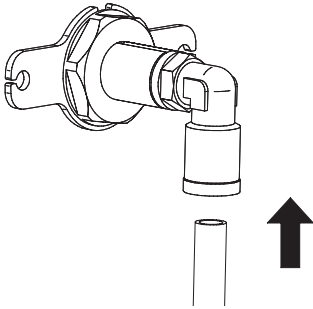

9
Push plastic inlet tubing all the way into the plastic elbow fitting.

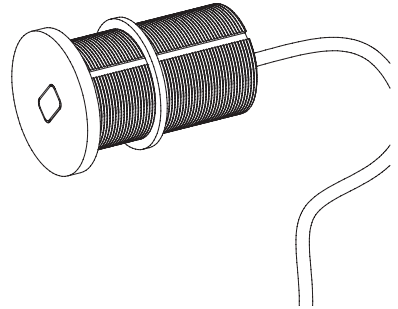

10
Insert the gasket into the shoulder of the sensor housing

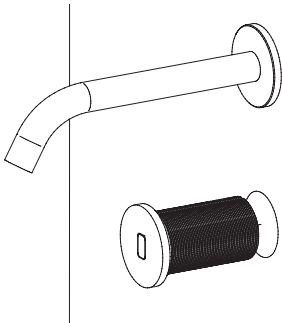

11
Slot the sensor housing assembly through the pre-drilled hole

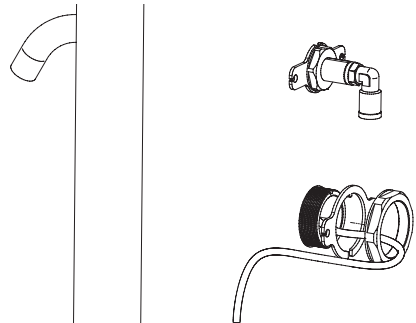

12
Fit the anti-rotational washer and locking nut onto the sensor housing and thread until hand tight.

how to install

Tap & Sensor Housing Installation

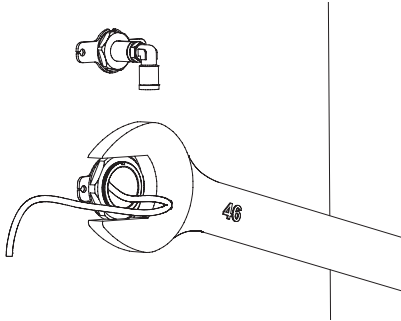

13

Tighten locking nut with a wrench and check sensor housing is aligned vertically and is square.

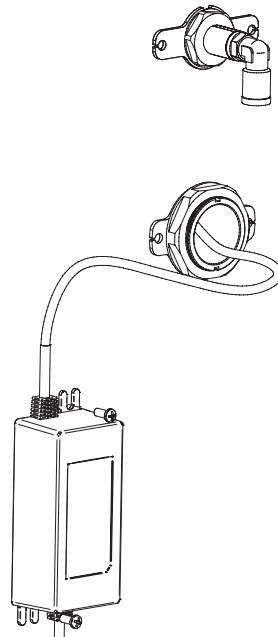

14

Fix the power supply to the wall or support ensuring the cables are long enough to connect to both the sensor and solenoid valve.

Solenoid Valve Installation

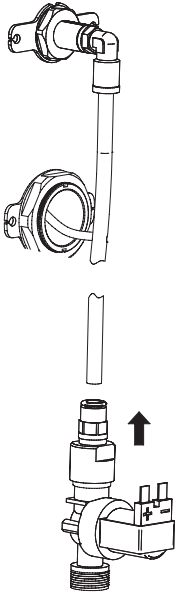

15

Trim any excess tubing not required and fit solenoid valve and reducing coupler assembly to plastic inlet tubing.

WARNING: Ensure both plastic push-fit connections are securely sealed with the plastic inlet tubing.

16

Connect the solenoid valve to the mains water supply using a brass fitting (not supplied) with ½" Female BSP connection.

Note: for USA installations, a BSP-NPT adaptor may be required to connect to the solenoid valve (refer to Spare Parts & Accessories on page 29).

Activation

17

The installation is now ready to commission.

commissioning

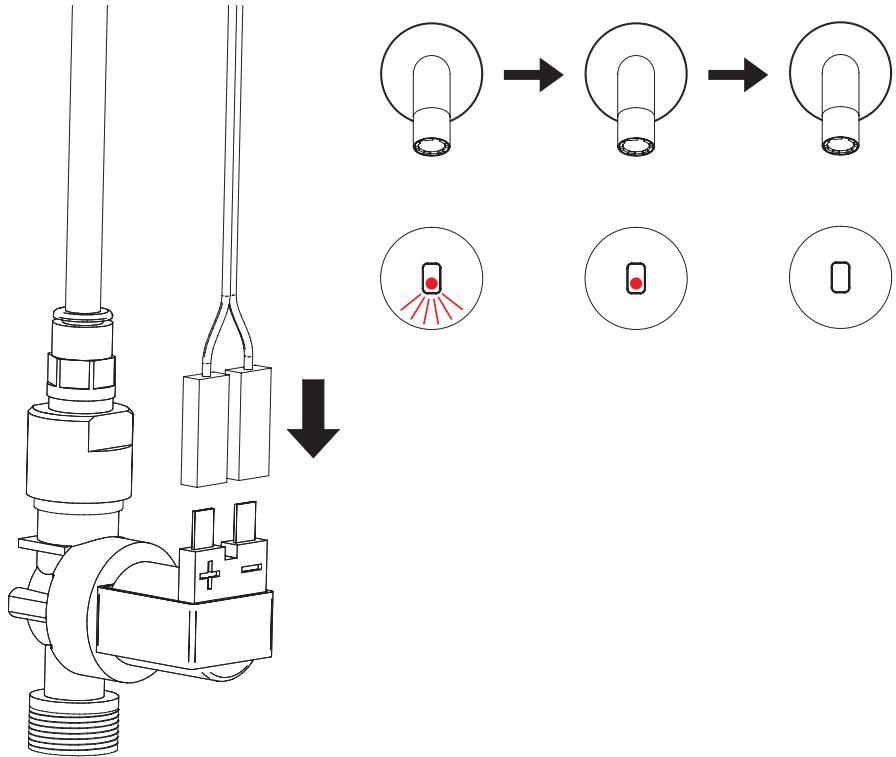

- + Connect the solenoid valve cable to the sensor.
- + Wait a minimum of 5 seconds.
- + Check the sensor mounted on the wall starts flashing red,
- + Once the red LED is flashing, position your hand within 2" of the tap.
- + When the red LED is continuously lit (and no longer flashing), position your hand at the desired activation position.
- + Wait until the red LED goes out before removing your hand
- + Once the red light goes out the pre-set range is set.

the complete system

FRONT

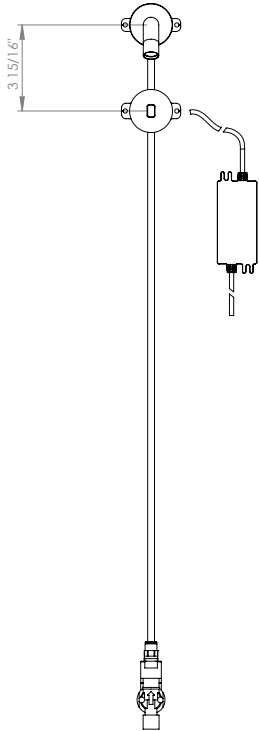

SIDE

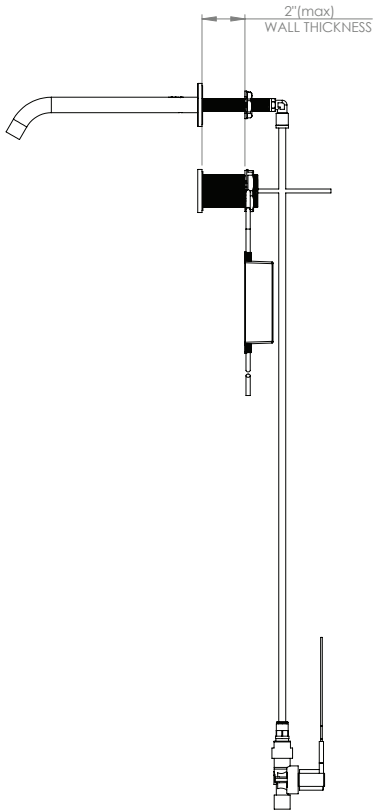

settings adjustment: wired controller

Disconnect the plug from the solenoid valve cable and connect to the wired controller to access information such as diagnostics, function and programmable settings (see table below).

Comfort Delay: keeps the water running for 2 seconds after there is no detection.

Security time-out after 30 seconds of continuous water flow the solenoid valve will close and the sensor will be blocked for 10 seconds. During this period the red LED will start flashing two times on repeat.

	Detection Range	Comfort delay	Security time-out	Auto-rinse cycle (after last activation)
Pre-set	8"*	2 seconds	30 seconds	Inactive
Programmable	8 - 9" Intervals: [2, 2 3/4, 4, 4 3/4, 6 3/4, 8, 9, 10"]	0 -100 seconds [1 sec intervals]	1 -240 seconds [1 sec intervals]	Inactive or Active Active: 6, 12 or 24 hours Rinse Duration: 10 - 180 seconds [10sec intervals]

*Pre-set detection range is valid for sensor for which the range has not been changed since factory-set. For sensors where the detection range has been changed this distance will be kept in memory even if reset to the appropriate mode using the controller.

maintenance

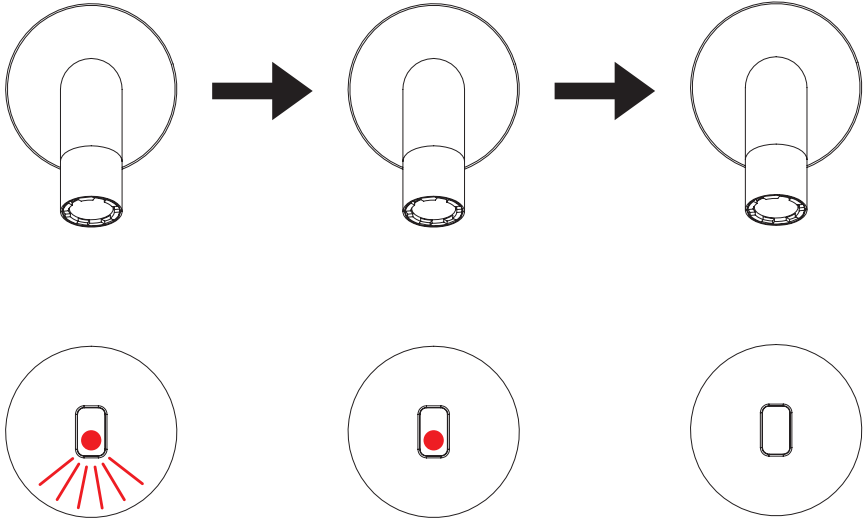

Re-setting the Sensor

- + Disconnect the sensor cable from the power supply.
- + Wait a minimum of 5 seconds and reconnect the power.
- + When the sensor mounted on the wall starts flashing red, position your hand within 2" of the tap.
- + When the red LED is continuously lit (and no longer flashing), position your hand at the desired activation position.
- + Wait until the red LED goes out before removing your hand
- + Once the red light goes out the new detection distance is set.
- + Test the system and repeat from step 1 until the tap works as required.

WARNING: Re-setting the sensor can lead to errors in the system with unnecessary activations or poor sensitivity. If you are considering altering the pre-set sensor settings, we recommend calling The Splash Lab for assistance.

maintenance

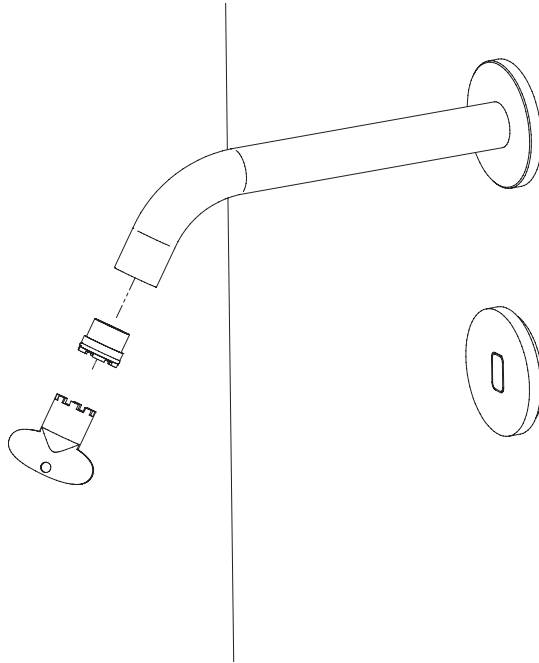

Changing the Aerator

- + Shut off the water supply to the tap.
- + Carefully unscrew the aerator using the supplied Aerator Key
- + Thread the new aerator taking care not to over tighten and damage the o-ring.
- + Reconnect water supply

Refer to Spare Parts & Accessories (page 29) for alternative aerators available.

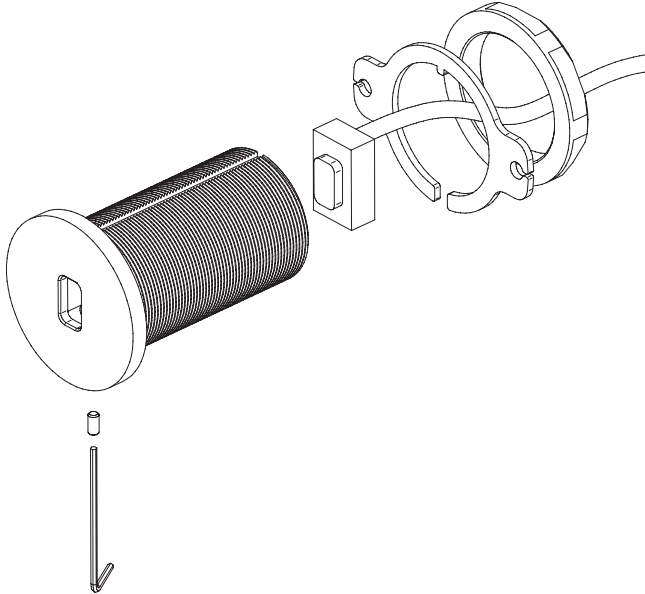

Changing the Sensor

- + Shut off the water supply to the tap.
- + Disconnect the sensor cable from the power supply
- + Loosen the locking nut for the sensor housing
- + Feed sensor housing back through the front of the wall
- + Using a 1.5 Hex/Allen key, loosen the grub screw taking care not to misplace it
- + Remove sensor
- + Insert new sensor and re-fit parts
- + Re-connect to power supply
- + Ensure sensor is set to the correct range

maintenance

Changing the Solenoid Valve

- + Shut off the water supply to the tap.
- + Disconnect the solenoid cable from the power supply.
- + Disconnect the solenoid valve from the brass reducing adaptor and the brass fitting attached to the mains water supply.
- + Remove the filter from the faulty solenoid valve.
- + Re-fit new filter to replacement solenoid valve.
- + Reassemble the parts as shown.
- + Restore the incoming water supply checking there are no water leaks.
- + Reconnect the solenoid cable to the power supply.

Note: the directional flow of water is shown on the solenoid housing with an arrow.

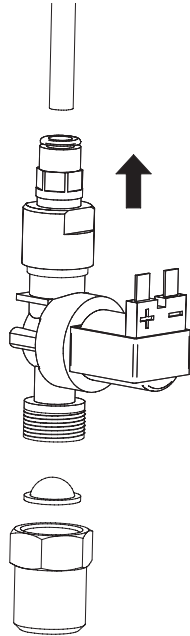

Cleaning the Solenoid Valve Filter

The tap is provided with a stainless steel filter preventing foreign particles to enter the lines. If the water flow has decreased, this may be because the filter is blocked.

- + Shut off the water supply to the tap.
- + Disconnect the solenoid cable from the power supply.
- + Disconnect the solenoid valve from the brass fitting attached to the mains water supply and locate the filter.
- + Wash the filter under running water to remove any debris.
- + Reassemble the parts as shown.
- + Restore the incoming water supply and check there are no water leaks.
- + Reconnect the solenoid cable to the power supply.

cleaning

- + Take extra care when cleaning decorative surfaces.
- + For surface cleaning of the tap use ONLY soap and water, then wipe dry with a clean cloth or towel.
- + DO NOT use steel wool or cleaning agents containing alcohol, acid, abrasives or the like.
- + Use of any prohibited cleaning or maintenance products or substances could damage the surface of the tap.
- + When cleaning bathroom tiles, the taps should be protected from any splattering of harsh cleansers.
- + For solenoid filter cleaning instructions see page 23.

diagram

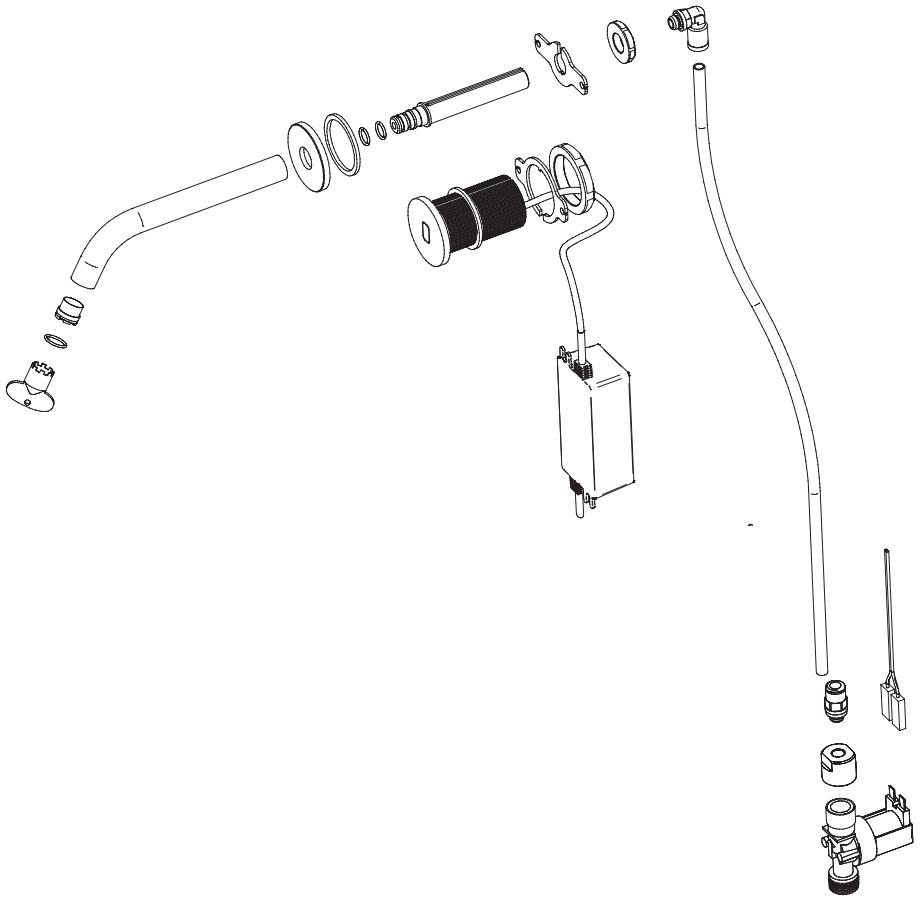

troubleshooting

Corrective Actions for Initial Installation Failures

No water flow out of the tap when user's hands are within sensor range:

- + No power
- + Range is too short
- + Range is too long
- + Sensor is dirty or covered.
- + Debris or scale in the solenoid.
- + Unit is in "Security time-out" mode
- + Check polarity of solenoid valve cable connection is correct
- + Sensor is picking up reflections from the washbasin or another object.

Water flow does not stop when user's hands are within sensor range:

- + Debris or scale in solenoid diaphragm.
- + Cables between the power supply and solenoid valve are disconnected.
- + Check polarity of solenoid valve cable connection is correct
- + The water supply pressure is too high
- + Check sensor setting with wired remote controller to ensure the sensor is set to Hand-wash mode

We are always looking to improve. If these did not solve your problem please contact us and we will endeavour to help.

Tel: +1 310 410 5008

Email: technical@thesplashlab.com

Corrective Actions for Initial Installation Failures

Slow response time when opening or closing solenoid valve:

- + Check all cable connections are secure
- + Check the tap is well isolated from the ground or the water.
- + Debris or scale in solenoid diaphragm.
- + Sensor is picking up reflections from the washbasin or another object.

Water flow rate reduced:

- + Aerator or solenoid valve filter is clogged.
- + Increase the sensor range (see page 18).
- + Decrease the sensor range (see page 18).
- + Remove obstruction to sensor.
- + Eliminate cause of reflection.
- + Unscrew top of solenoid from body, pull out the plunger and the spring from the solenoid and clean them. Use scale remover material if needed. When replacing the plunger, please make sure that the spring is in the vertical position.
- + Clean the solenoid orifice or replace the diaphragm.
- + Reduce the water supply pressure.
- + Remove, clean and re-install

warranty

We believe the future is personal. With a global mindset, we challenge conventional restroom norms via product innovation to create considered washroom solutions for corporate and educational spaces. We use rich raw materials, cutting-edge automation and considered washroom design to powerfully and positively influence the lives of people. We are The Splash Lab.

Demonstrating our commitment to quality and our belief in the strength of our designs, we can offer the following warranties.

The Splash Lab will warrant that its products will be free of manufacturing and material defects during normal use and environmental conditions as detailed below:

Sensor taps 2 years' parts & labour

If a defect is found in normal use, The Splash Lab will, at their discretion, repair, provide a replacement part or product, or make appropriate adjustments. Damage caused by accident, misuse, or abuse is not covered by this warranty. Improper care and cleaning will void the warranty.

Non-operation of the product due to environmental conditions beyond our control, installation error, incorrect maintenance, water quality, fair wear and tear, incorrect or inappropriate installation, misuse and abuse is not covered by the warranty.

Proof of purchase (original sales receipt) must be provided to The Splash Lab with all warranty claims.

The above warranty is valid for goods supplied within North America.

For goods supplied outside of North America, The Splash Lab will honour the above stated warranty periods for the parts only.

THE SPLASH LAB DISCLAIM ANY LIABILITY FOR SPECIAL, INCIDENTAL OR CONSEQUENTIAL DAMAGES.

spare parts & accessories

Spare Parts

L120030	Solenoid valve assembly
L120032	Solenoid valve connector cable
L260014	IR Sensor
L270024	Power Supply 110~240V AC / 6V DC
L230161	Sensor Tap Extension Cable 4'
L260050	CACHE-TT Aerator Key
L260054	CACHE-TT Aerator PCA Laminar 0.5GPM

Accessories

L260051	CACHE-TT Aerator PCA Spray 0.35GPM
L260052	CACHE-TT Aerator PCA Laminar 1.0GPM
L260053	Straight Adaptor (½" BSP Female x ½" NPT Male)
L120020	Daisy Chain Enclosure
L120021	Daisy Chain Cable
L23009	Wired Controller RIO14-WP

If further information is required, contact The Splash Lab technical team for more detailed guidelines

drilling template

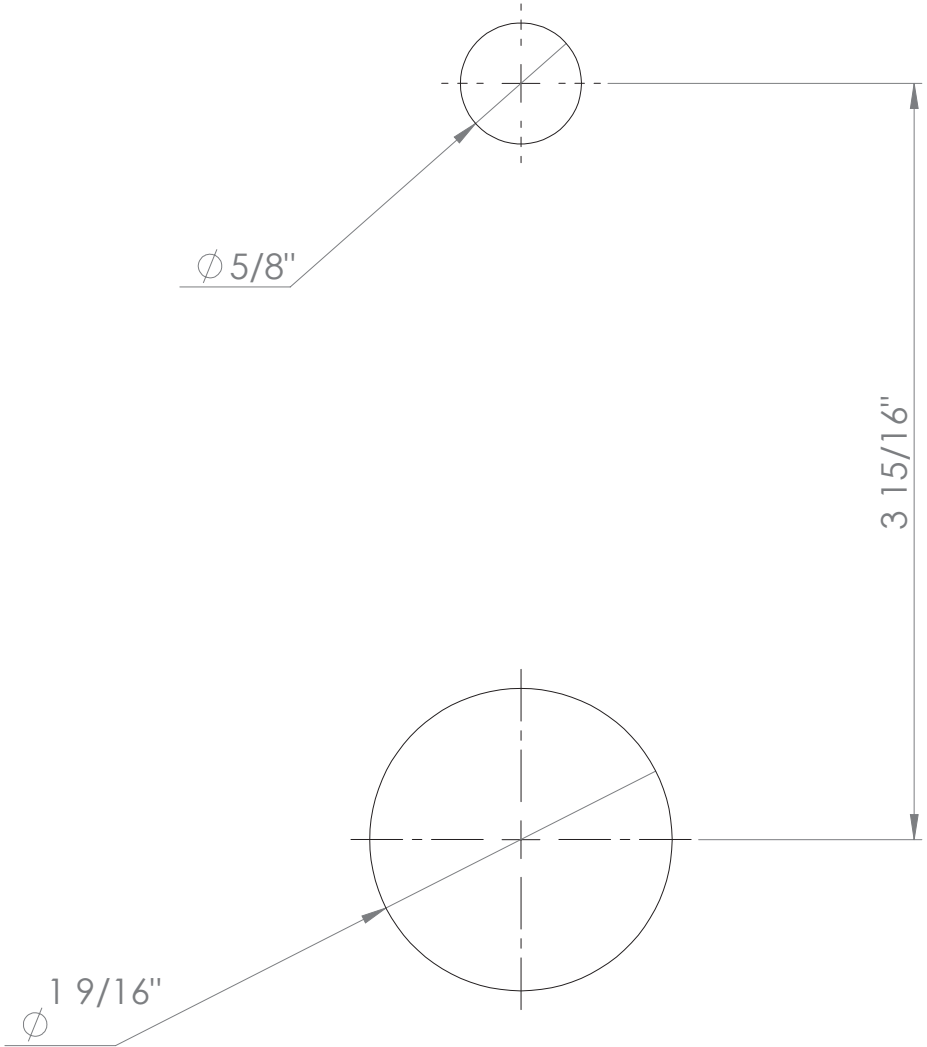

contact



General information

info@thesplashlab.com

+1 310 410 5008

Studio D, 8745 Washington Blvd, Culver city, CA 90232

Technical support

technical@thesplashlab.com

For further contact information visit:

www.thesplashlab.com

